

5301065
MODEL NO. LG-2500-303
12 Volt Lawn & Garden Sprayer
ASSEMBLY / OPERATION INSTRUCTIONS / PARTS

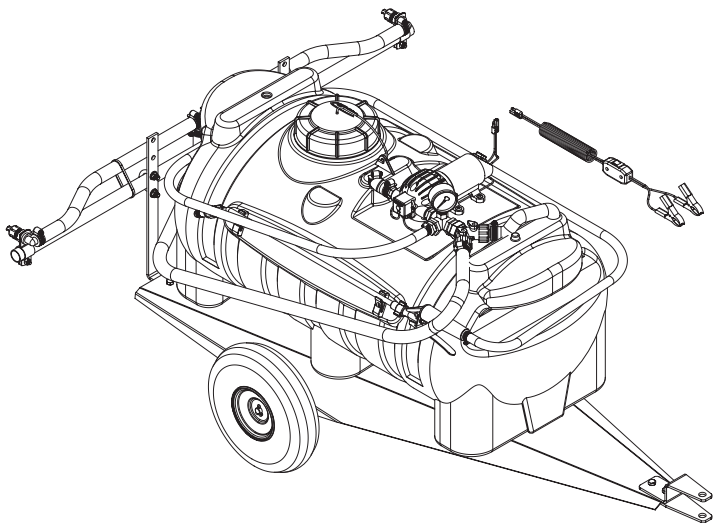

GENERAL INFORMATION

The purpose of this manual is to assist you in operating and maintaining your lawn and garden sprayer. Please read it carefully as it furnishes information which will help you achieve years of dependable trouble free operation.

WARRANTY / PARTS / SERVICE

Products are warranted for one year from date of purchase against manufacturer or workmanship defects.

Your authorized dealer is the best source of replacement parts and service. To obtain prompt, efficient service, always remember to give the following information:

1. Correct part description and part number.
2. Model Number of your sprayer.
3. Serial Number of your sprayer.

Part description and part numbers can be obtained from the illustrated parts list section of this manual.

Whenever you need parts or repair service, contact your distributor / dealer first. For warranty work always take your original sales slip, or other evidence of purchase date, to your distributor / dealer.

TECHNICAL SPECIFICATIONS

- Low Profile Trailer and Tank
- Polyethylene Tank
- 4.10/3.50 x 4 Pneumatic Tires

- 12 Volt Diaphragm Pump
- 2.1 G.P.M.
- Lever Handgun
- 15 Ft. of 3/8" Hose (Handgun)
- Pressure Gauge
- Adjustable Pressure Range (0-60 PSI Max.)
- Boom-2 Nozzles, 80" Coverage

ASSEMBLY INSTRUCTIONS

1. Bolt the hitch brackets (formed and flat) to the frame as shown in the exploded view drawing. Use (2) 5/16" x 3/4" hex bolts and (2) 5/16" hex whiz locknuts.
2. Bolt the boom mounting brackets (Item 17) to the underside of the frame (see exploded view drawing). Use (2) 5/16" x 3/4" hex bolts & (2) 5/16" hex whiz locknuts for each bracket.
3. Slide the axle through the frame holes. Slide a spacer (Item 21) on each end of the axle after the axle is positioned in the frame holes. Slide the wheels onto the axle (valve stem out), securing them in place with a cotter pin on each end.
4. Attach the boom assembly to the boom mounting brackets so that the tips will be about 18 inches above the spraying surface. Use the (2) U-bolts (Item 9) and (4) 5/16" hex whiz locknuts to secure the boom (w/harness) in place.

NOTE: The nozzles may be mounted on the top side of the boom tube or on the bottom side, at the owner's discretion.

5. Attach the boom feed line hose to the boom & secure in place with a 1/2" hose clamp.
6. Remove the pressure gauge and the handgun clips from the parts bag. Thread the gauge into the "gauge tee" (Item 5.1) in the pump sub-assembly drawing) using a good grade of thread sealant to prevent any leaks. Attach the (2) handgun clips to the side of the tank with the screws provided.



WWW.FIMCOINDUSTRIES.COM

1000 FIMCO LANE • P.O. BOX 1700 • NO. SIOUX CITY, SD 57049
TOLL FREE: 800-831-0027 • TOLL FREE FAX: 800-494-0440
Form No. 523 (5004452 8/06) Printed In U.S.A.

- Join the red wire of the two-wire cable to a "hot" connection on the vehicle, such as a switch, ammeter, or the positive battery post. The brown wire (of the two-wire cable) should be grounded or connected to the negative battery post.

Read the operating instructions and then run the sprayer using only water for testing. Initially begin spraying by closing the bypass regulating valve and opening the shut-off valve to the boom. This will enable the air in the line to be eliminated through the tips, while building pressure. When everything tests all right (no leaks, good pressure), add the desired chemicals mixture and water combination and start the spraying operation.

OPERATION

This sprayer is designed to be towed behind a garden tractor.

The pumping system draws solution from the tank, through the strainer and to the pump. The pump forces the solution under pressure to the boom nozzles.

The pump has a pressure switch which will shut the pump off when it reaches 60 PSI.

Pressure may be decreased by opening the bypass valve (Hi-Lo). The more it is opened, the lower the pressure will be.

The nozzles on the boom will spray an 80 inch wide swath. Check the nozzle spray pattern by spraying water on a concrete surface. Raise the boom to get more spray pattern overlap if desired.

Regularly clean the intake tube screen by removing the screen from the intake tube. The screen may now be tapped or flushed with clear water for cleaning.

WARNING: Some chemicals will damage the pump valves if allowed to soak untreated for a length of time. Always flush the pump with water after use. Do not allow chemicals to sit in pump for extended times of idleness. Follow chemical manufacturers instructions on disposal of all waste water from the sprayer.

CALIBRATION

Chemical labels may show application rates in gallons per acre, gallons per 1000 square feet or gallons per 100 square feet. You will note that the tip chart shows all three of these rating systems.

Once you know how much you are going to spray then determine (from the tip chart) the spraying pressure (PSI), and the spraying speed (MPH).

Conditions of weather and terrain must be considered when setting the sprayer. Do not spray on windy days. Protective clothing must be worn in some cases. **Be sure to read the chemical label carefully.**

Determining the proper speed of the tractor can be done by marking off 100, 200 and 300 feet. The speed chart indicates the number of seconds it takes to travel the distances. Set the throttle and with a running start travel the distances. Adjust the throttle until you travel the distances in the number of seconds indicated by the speed chart. Once you have reached the throttle setting needed, mark the throttle location so you can stop and go again (returning to the same speed).

Add water and proper amount of chemical to tank and drive to the starting place for spraying.

When you are ready to spray, turn the boom valve to the "on" position. This will start solution spraying from the tips. The pressure will decrease slightly when the boom is spraying.

Tip Chart

Tip No.	Spray Height	Pressure (PSI)	Capacity (GPM)	GALLONS PER ACRE - BASED ON WATER							
				1 MPH	2 MPH	3 MPH	4 MPH	5 MPH	7.5 MPH	10 MPH	
3	18"	10	.30	44	22	14.9	11.1	8.9	5.9	4.5	
		20	.42	63	31.5	20.9	15.7	12.6	8.4	6.3	
		30	.52	76	38	26	19.3	15.4	10.3	7.7	
		40	.60	90	45	30	22	17.8	11.8	8.9	
Tip No.	Spray Height	Pressure (PSI)	Capacity (GPM)	GALLONS PER 1000 SQ. FT. - BASED ON WATER							
				1 MPH	2 MPH	3 MPH	4 MPH	5 MPH	7.5 MPH	10 MPH	
3	18"	10	.30	1.01	.50	.34	.254	.204	.135	.103	
		20	.42	1.4	.72	.48	.36	.29	.19	.14	
		30	.52	1.74	.87	.596	.44	.35	.236	.176	
		40	.60	2.06	1.00	.688	.50	.408	.27	.20	
Tip No.	Spray Height	Pressure (PSI)	Capacity (GPM)	GALLONS PER 100 SQ. FT. - BASED ON WATER							
				1 MPH	2 MPH	3 MPH	4 MPH	5 MPH	7.5 MPH	10 MPH	
3	18"	10	.30	.10	.050	.034	.025	.020	.013	.010	
		20	.42	.14	.072	.048	.036	.029	.019	.014	
		30	.52	.174	.087	.059	.044	.035	.0236	.017	
		40	.60	.206	.1	.068	.050	.040	.027	.020	

Speed Chart

Speed in M.P.H. (Miles Per Hour)	Time Required in Seconds to Travel a distance of;		
	100 ft.	200 ft.	300 ft.
1.0	68	136	205
2.0	34	68	102
3.0	23	45	68
4.0	17	34	51
5.0	14	27	41
6.0	11	23	34
7.0	9.7	19	29
8.0	8.5	17	26
9.0	7.6	15	23
10	6.8	14	20

AFTER SPRAYING

After use fill the sprayer part way with water. Start the sprayer and allow clear water to be pumped through the plumbing system and out through the spray nozzles.

Refill the tank about half full with plain water and use a chemical neutralizer such as Nutra-Sol or equivalent and repeat cleaning instructions. Flush the entire sprayer with the neutralizing agent. Follow the chemical manufacturers disposal instructions of all wash or rinsing water.

Remove tips and screens from the boom. Wash tips thoroughly with water or cleaning solution (appropriate for chemical used). Blow out orifice, clean and dry. If orifice remains clogged clean it with a fine bristle (not wire) brush, or with a tooth pick. Do not damage the orifice. Water rinse and dry tips before storing.

WINTER STORAGE

Drain all water and chemical out of sprayer, paying special attention to pump and valves. These items are especially prone to damage from chemicals and freezing weather.

The sprayer should be winterized before storage by pumping a solution of RV antifreeze through the entire plumbing. Proper care and maintenance will prolong the life of the sprayer.

Exploded View of Pump #5275016

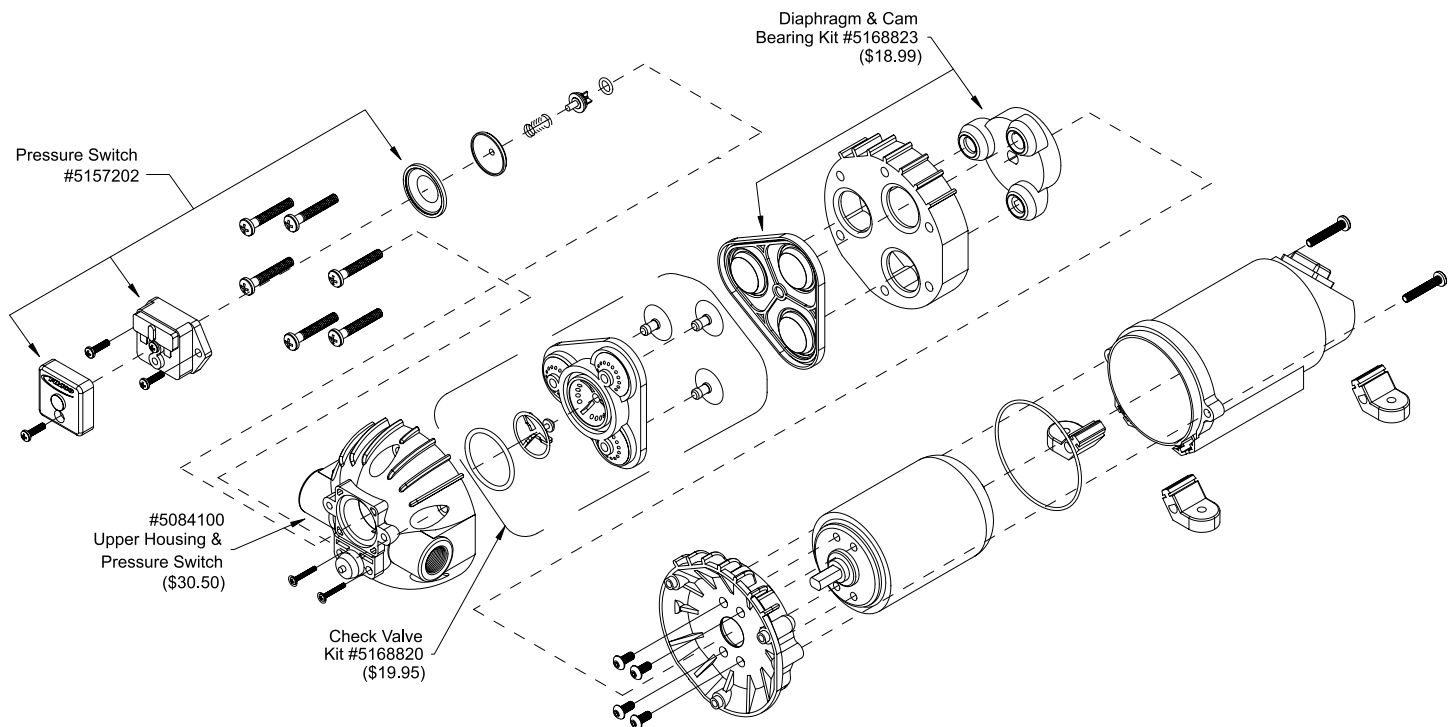

Pump Sub-Assembly #5275147

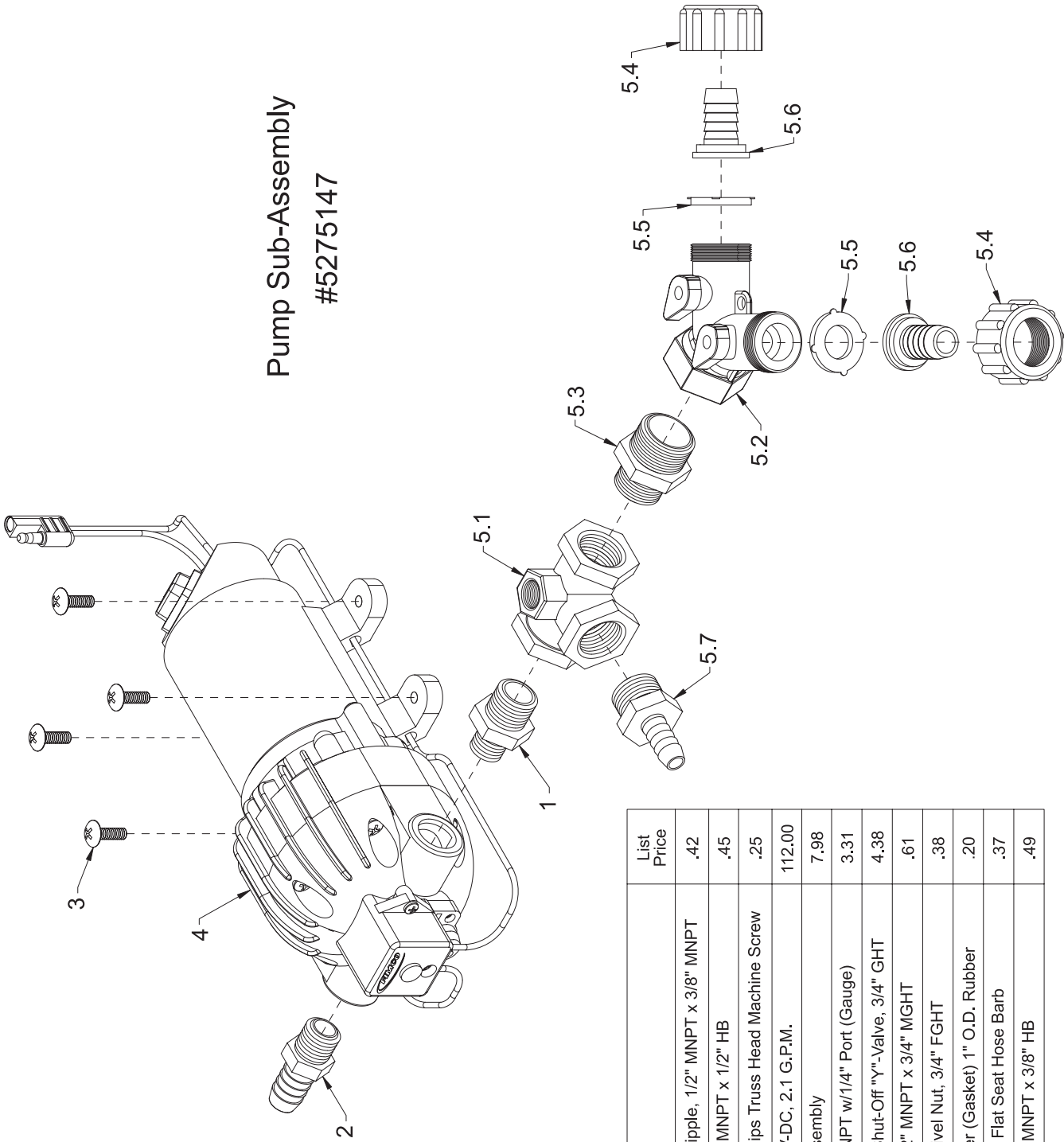

Item No.	Part Number	Qty	Description	List Price
1	5011128	1	Nylon Reducing Nipple, 1/2" MNPT x 3/8" MNPT	.42
2	5067021	1	Nylon Fitting, 3/8" MNPT x 1/2" HB	.45
3	5117167	4	#10-24 x 5/8" Phillips Truss Head Machine Screw	.25
4	5275016	1	Triplex Pump, 12V-DC, 2.1 G.P.M.	112.00
5	5275118	1	Plumbing Sub-Assembly	7.98
5.1	5010193	1	Nylon Tee, 1/2" FNPT w/1/4" Port (Gauge)	3.31
5.2	5143204	1	#235 Dual Hose Shut-Off "Y"-Valve, 3/4" GHT	4.38
5.3	5005021	1	Nylon Adapter, 1/2" MNPT x 3/4" MGHT	.61
5.4	5006055	2	Nylon Knurled Swivel Nut, 3/4" FGHT	.38
5.5	5016066	2	#102 Hose Washer (Gasket) 1" O.D. Rubber	.20
5.6	5149011	2	Nylon Swivel, 1/2" Flat Seat Hose Barb	.37
5.7	5067016	1	Nylon Fitting, 1/2" MNPT x 3/8" HB	.49

Exploded View/Parts List LG-2500-303

Item No.	Part Number	Qty	Description	List Price
1	5006307	10	5/16"-18 Hex Whiz (Flange) Locknut	.09
2	5020060	1	Hose, 1/2"-1 Brd. x 2 3/4"	.64
3	5020122	1	Hose, 1/2"-1 Brd. x 48"	5.88
4	5020215	1	Hose, 3/8"-1 Brd. x 15 Ft.	8.50
5	5020241	1	Hose, 1/2"-1 Brd. x 6"	1.51
6	5021030	2	4.10/3.50 x 4" Wheel (White) w/2 1/4" Offset Hub	16.26
7	5024077	1	Axle, 24"	7.47
8	5034038	6	H.H.C.S., 5/16"-18 x 3/4"	.55
9	5034220	2	Round U-Bolt, 5/16"-18 x 1 5/16" x 1 3/4"	.50
10	5034531	4	5/16"-18 x 5/8" Flange Lock Screw	.44
11	5038517	1	Hitch Bracket (Formed)	4.85
12	5038518	1	Hitch Bracket (Flat)	2.30
13	5051022	5	Hose Clamp, 1/2"	.62
14	5051114	2	Hose Clamp, 3/8"	.63
15	5058183	1	FIMCO 5" Threaded Tank Lid w/Lanyard	10.50
16	5070044	1	LG-2500 Frame	54.00
17	5095116	2	Boom Mount Bracket	5.57
18	5100275	1	Intake Tube (25 Gallon)	1.40
19	5101077	2	Colter Pin, 1/8" x 1"	.25
20	5116251	1	Strainer, Suction Line	1.99
21	5127118	2	Wheel Spacer	.50
22	5163100	1	Low Flow Handgun w/X-26 Adjustable Tip, 29 1/2" Wand	9.95
23	5167007	1	Gauge, 0-100 p.s.i.	5.99
24	5169206	1	25 Gallon Blowmolded Tank (w/2 Holes)	64.95
25	5273783	1	2-Nozzle Boom Assembly	28.90
26	5274373	1	Drain Plug Cap, Tether, and Washer Assembly	2.95
26.1	5102117	1	Drain Plug Cap, Black, for Blow-Molded Tanks	.99
26.2	5058171	1	Drain Cap Tether	.30
26.3	5072507	1	Drain Cap Washer	.20
27	5274443	1	Lead Wire Assembly (w/Switch), 96"	13.50
28	5274880	1	Pkg. (2) Handgun Clips & (2) Screws	2.85
28.1	5053096	2	Handgun Clip, for Blow-Molded Tanks	.95
28.2	5117293	2	#10-24 x 3/8" Phillips Round Head Machine Screw	.25
29	5275147	1	Pump Sub-Assembly w/Triplex Pump	127.00

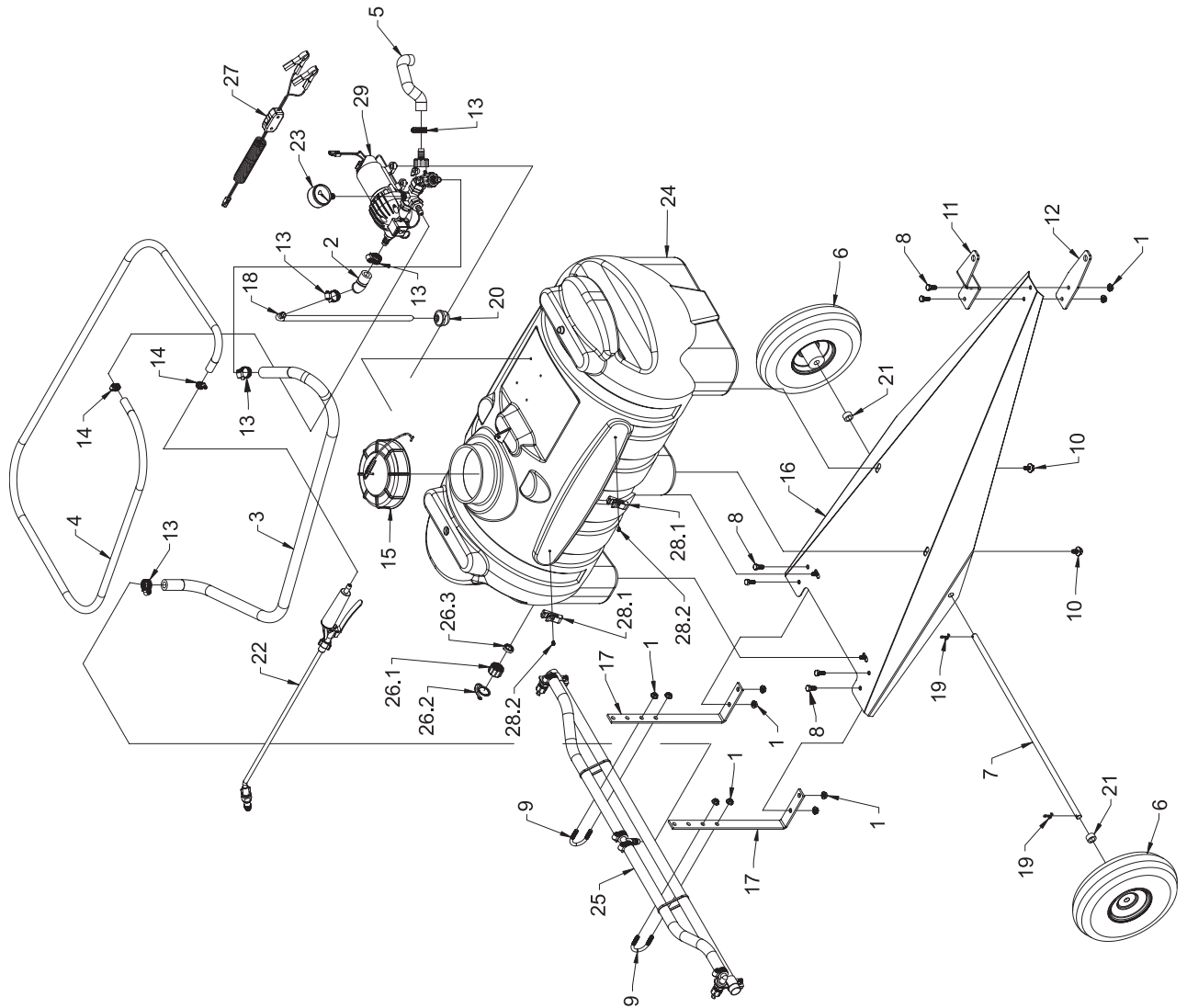

Exploded View/Parts List
 2-Nozzle Boom Assembly
 #5273783

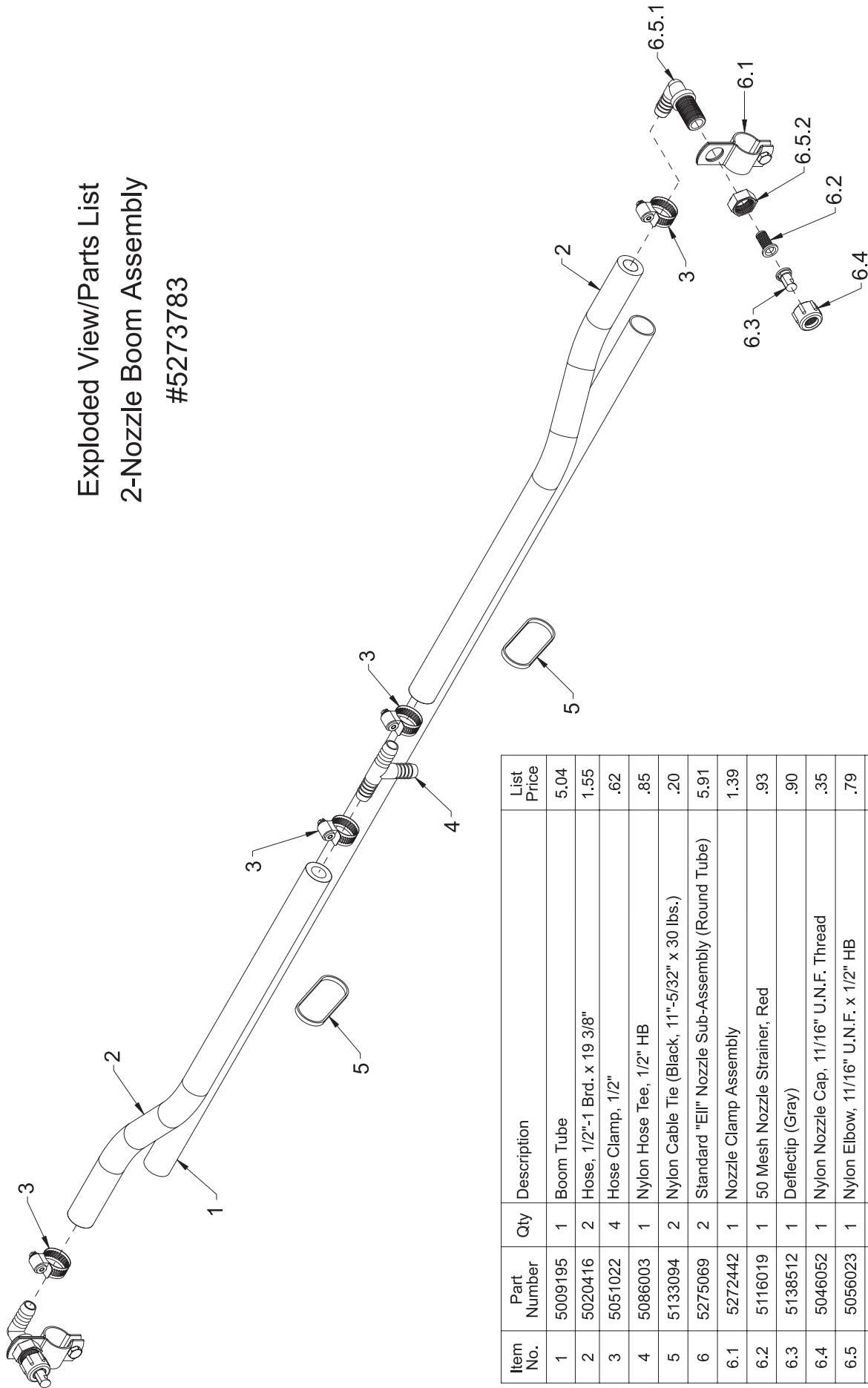

Item No.	Part Number	Qty	Description	List Price
1	5009195	1	Boom Tube	5.04
2	5020416	2	Hose, 1/2"-1 Brd. x 19 3/8"	1.55
3	5051022	4	Hose Clamp, 1/2"	.62
4	5086003	1	Nylon Hose Tee, 1/2" HB	.85
5	5133094	2	Nylon Cable Tie (Black, 11"-5/32" x 30 lbs.)	.20
6	5275069	2	Standard "Eli" Nozzle Sub-Assembly (Round Tube)	5.91
6.1	5272442	1	Nozzle Clamp Assembly	1.39
6.2	5116019	1	50 Mesh Nozzle Strainer, Red	.93
6.3	5138512	1	Deflectip (Gray)	.90
6.4	5046052	1	Nylon Nozzle Cap, 11/16" U.N.F. Thread	.35
6.5	5056023	1	Nylon Elbow, 11/16" U.N.F. x 1/2" HB	.79
6.5.1	5056023	1	Nylon Elbow, 11/16" U.N.F. x 1/2" HB	.79
6.5.2	5006184	1	Nylon Nozzle Nut	.26