

**5301242**  
**Model: ATV-25**  
**12 VOLT - 25 GALLON LAWN & GARDEN SPRAYER**

**ASSEMBLY / OPERATION INSTRUCTIONS / PARTS**

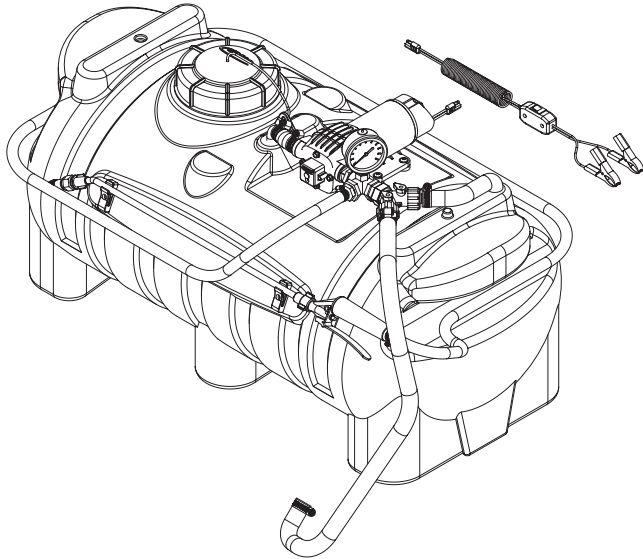

**GENERAL INFORMATION**

The purpose of this manual is to assist you in operating and maintaining your ATV mounted sprayer. Please read it carefully as it furnishes information which will help you achieve years of dependable trouble free operation.

**WARRANTY / PARTS / SERVICE**

Products are warranted for one year from date of purchase against manufacturer or workmanship defects.

Your authorized dealer is the best source of replacement parts and service. To obtain prompt, efficient service, always remember to give the following information:

1. Correct part description and part number.
2. Model Number of your sprayer.
3. Serial Number of your sprayer.

Part description and part numbers can be obtained from the illustrated parts list section of this manual.

Whenever you need parts or repair service, contact your distributor / dealer first. For warranty work always take your original sales slip, or other evidence of purchase date, to your distributor / dealer.

**TECHNICAL SPECIFICATIONS**

- Corrosion Resistant Polyethylene Tank
- 12 Volt Diaphragm Pump - 45 P.S.I.
- Pressure Gauge-Adjustable Pressure Range
- 15 Foot Handgun Hose

The sprayer may be mounted to most makes of agricultural ATV vehicles.

**CAUTION: Always check the vehicle load rating before using this sprayer. The loaded weight of the sprayer and boom assembly is about 250 lbs. when the tank is full. Care must be taken not to tip the vehicle over backwards, especially when starting or accelerating.**

**ASSEMBLY**

This sprayer is partially assembled at the factory. Assembly may be completed by following these steps.

1. Secure the sprayer onto the carrier rack of your ATV as needed.
2. Connect the wiring from the pump to the 12 volt power source of the vehicle. The red wire of the two wire set must be connected to the positive post on the battery or the "Hot" connection on a switch or to the ammeter. The brown wire may be grounded or connected to the negative battery post.
3. The pressure gauge is shipped in a parts bag. Thread the gauge into the fitting as shown on the exploded view drawing.

**OPERATION**

The pumping system draws solution from the tank, through the strainer, and to the pump. The pump forces the solution under pressure to the handgun or boom nozzles.

Pressure may be increased by closing the finger knob on the "Y" valve. The more it is opened, the lower the pressure will be.

- Open the handgun by squeezing the handle lever
- Rotating the adjustable nozzle tip on the handgun will change the tip from a straight stream to a cone pattern



WWW.FIMCOINDUSTRIES.COM

1000 FIMCO LANE • P.O. BOX 1700 • NO. SIOUX CITY, SD 57049  
TOLL FREE: 800-831-0027 • TOLL FREE FAX: 800-494-0440  
Form No. 1227 (5004753 6/06) Printed In U.S.A.

(finer mist). Note: The pump will cycle when the handgun is adjusted to the cone pattern.

- The pump motor's demand switch shuts off the motor when the handgun and boom lines are fully closed. This is normal unless the bypass line is open. All lines must be closed so pressure will increase to that pressure where the pump is set to shut down. The system remains pressurized, and the pump motor will restart automatically when the handgun or boom line is opened.
- It is important to test the sprayer with plain water before adding chemical to the solution.

**WARNING:** Some chemicals will damage the pump valves if allowed to soak untreated for a length of time. Always flush the pump with water after use. Do not allow chemicals to sit in pump for extended times if idleness. Follow chemical manufacturers instructions on disposal of all waste water from the sprayer.

### CALIBRATION

Chemical labels may show application rates in gallons per acre, gallons per 1000 square feet, or gallons per 100 square feet. You will note that the tip chart below shows all three of these rating systems.

Once you know how much you are going to spray then determine (from the tip chart) the spraying pressure (PSI), and the spraying speed (MPH).

### MEASURING TRAVEL SPEED

Measure a test course in the area to be sprayed or in an area with similar surface conditions. Lengths of 100, 200, & 300 ft. are recommended for measuring speeds from 1-10 mph respectively. Determine the time required to travel the test course. To help insure accuracy, conduct the speed check with a loaded sprayer and select the engine throttle setting and gear that will be used when spraying. Repeat the above process and average the times that were measured. Use the following table below to determine ground speed.

After all calibrations have been completed, add water and chemical to the tank. Always follow chemical manufacturers instructions for mixing.

### GROUND SPEED CHART

Speed in M.P.H. (Miles Per Hour)	Time Required in Seconds to Travel a distance of:		
	100 ft.	200 ft.	300 ft.
1.0	68	136	205
2.0	34	68	102
3.0	23	45	68
4.0	17	34	51
5.0	14	27	41
6.0	11	23	34
7.0	9.7	19	29
8.0	8.5	17	26
9.0	7.6	15	23
10	6.8	14	20

Conditions of weather and terrain must be considered when setting the sprayer. Do not spray on windy days. Protective clothing must be worn in some cases. **Be sure to read the chemical label carefully.**

Add water to the tank and drive to the starting place for testing. Adjust pressure to 30 PSI. Start the solution spraying from the tips and handgun. Check for pressure and leaks.

After testing you may mix the chemical and water into the tank and start spraying

### AFTER SPRAYING

After use fill the sprayer part way with water, start the sprayer and allow clear water to be pumped through the plumbing system and out through the spray nozzles.

### Tip Chart

Tip No.	Spray Height	Pressure (PSI)	Capacity (GPM)	GALLONS PER ACRE - BASED ON WATER						
				1 MPH	2 MPH	3 MPH	4 MPH	5 MPH	7.5 MPH	10 MPH
3	18"	10	.30	44	22	14.9	11.1	8.9	5.9	4.5
		20	.42	63	31.5	20.9	15.7	12.6	8.4	6.3
		30	.52	76	38	26	19.3	15.4	10.3	7.7
		40	.60	90	45	30	22	17.8	11.8	8.9

Tip No.	Spray Height	Pressure (PSI)	Capacity (GPM)	GALLONS PER 1000 SQ. FT. - BASED ON WATER						
				1 MPH	2 MPH	3 MPH	4 MPH	5 MPH	7.5 MPH	10MPH
3	18"	10	.30	1.01	.50	.34	.254	.204	.135	1.03
		20	.42	1.4	.72	.48	.36	.29	.19	.14
		30	.52	1.74	.87	.596	.44	.35	.236	.176
		40	.60	2.06	1.00	.688	.50	.408	.27	.20

Tip No.	Spray Height	Pressure (PSI)	Capacity (GPM)	GALLONS PER 100 SQ. FT. - BASED ON WATER						
				1 MPH	2 MPH	3 MPH	4 MPH	5 MPH	7.5 MPH	10MPH
3	18"	10	.30	.10	.050	.034	.025	.020	.013	.010
		20	.42	.14	.072	.048	.036	.029	.019	.014
		30	.52	.174	.087	.059	.044	.035	.0236	.017
		40	.60	.206	.1	.068	.050	.040	.027	.020

Refill the tank about half full with plain water and use a chemical neutralizer such as Nutra-Sol or equivalent and repeat cleaning instructions above. Flush the entire sprayer with the neutralizing agent. Follow the chemical manufacturers disposal instructions of all wash or rinsing water.

Remove tips and screens from your boom. Wash tips thoroughly with water or cleaning solution (appropriate for chemical used). Blow out orifice, clean and dry. If orifice remains clogged, clean it with a fine bristle (not wire) brush, or with a toothpick. Do not damage the orifice. Water rinse and dry tips before storing.

### WINTER STORAGE

Drain all water out of sprayer paying special attention to pump, handgun & valve. These items are especially prone to damage from chemicals and freezing weather.

The sprayer should be winterized before storage by pumping a solution of RV anti-freeze through the entire plumbing. Proper care and maintenance will prolong the life of the sprayer.

Exploded View/Parts List:  
Pump #5275017

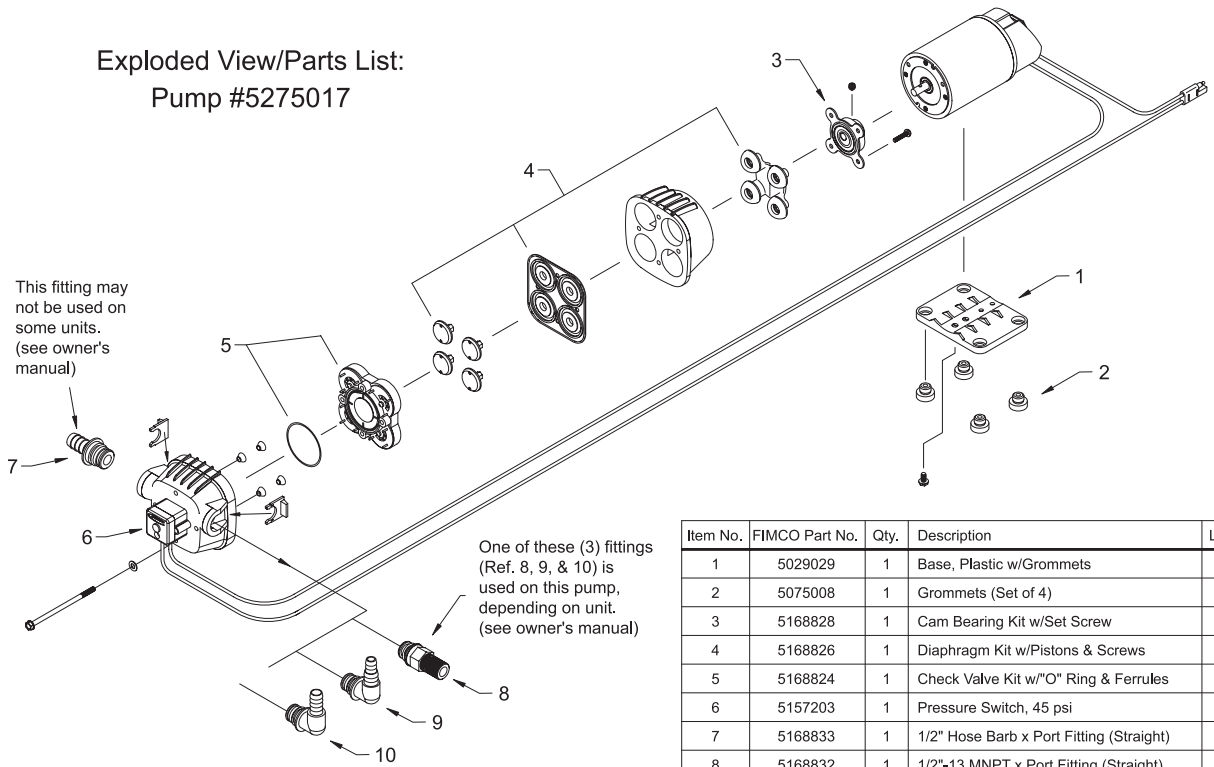

Item No.	FIMCO Part No.	Qty.	Description	List Price
1	5029029	1	Base, Plastic w/Grommets	9.25
2	5075008	1	Grommets (Set of 4)	1.82
3	5168828	1	Cam Bearing Kit w/Set Screw	—
4	5168826	1	Diaphragm Kit w/Pistons & Screws	19.96
5	5168824	1	Check Valve Kit w/"O" Ring & Ferrules	24.99
6	5157203	1	Pressure Switch, 45 psi	24.95
7	5168833	1	1/2" Hose Barb x Port Fitting (Straight)	2.24
8	5168832	1	1/2"-13 MNPT x Port Fitting (Straight)	2.24
9	5010424	1	3/8" Hose Barb Elbow x Port Fitting	1.50
10	5010426	1	1/2" Hose Barb Elbow x Port Fitting	1.49

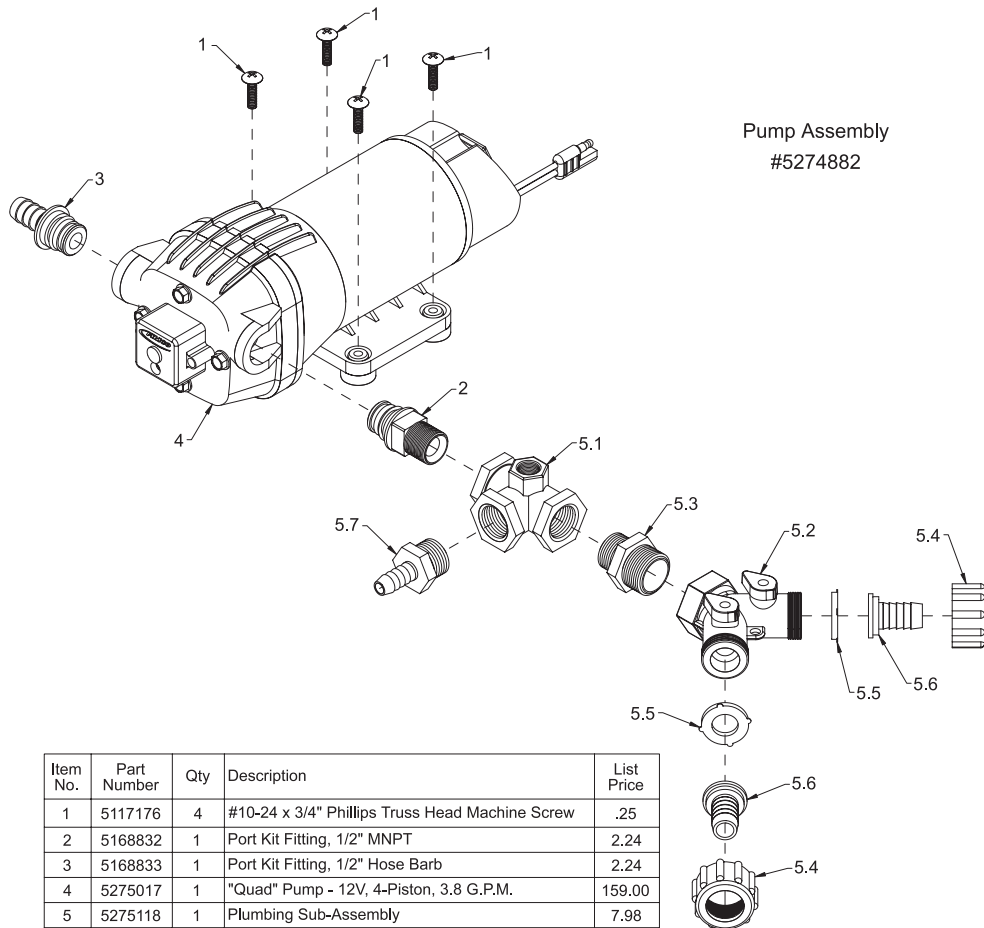

Item No.	Part Number	Qty	Description	List Price
1	5117176	4	#10-24 x 3/4" Phillips Truss Head Machine Screw	.25
2	5168832	1	Port Kit Fitting, 1/2" MNPT	2.24
3	5168833	1	Port Kit Fitting, 1/2" Hose Barb	2.24
4	5275017	1	"Quad" Pump - 12V, 4-Piston, 3.8 G.P.M.	159.00
5	5275118	1	Plumbing Sub-Assembly	7.98
5.1	5010193	1	Nylon Tee, 1/2" FNPT w/1/4" Port (Gauge)	3.31
5.2	5143204	1	#235 Dual Hose Shut-Off "Y"-Valve, 3/4" GHT	4.38
5.3	5005021	1	Nylon Adapter, 1/2" MNPT x 3/4" MGHT	.61
5.4	5006055	2	Nylon Knurled Swivel Nut, 3/4" FGHT	.38
5.5	5016066	2	#102 Hose Washer (Gasket) 1" O.D. Rubber	.20
5.6	5149011	2	Nylon Swivel, 1/2" Flat Seat Hose Barb	.37
5.7	5067016	1	Nylon Fitting, 1/2" MNPT x 3/8" HB	.49

Exploded View/Parts List:

ATV-25

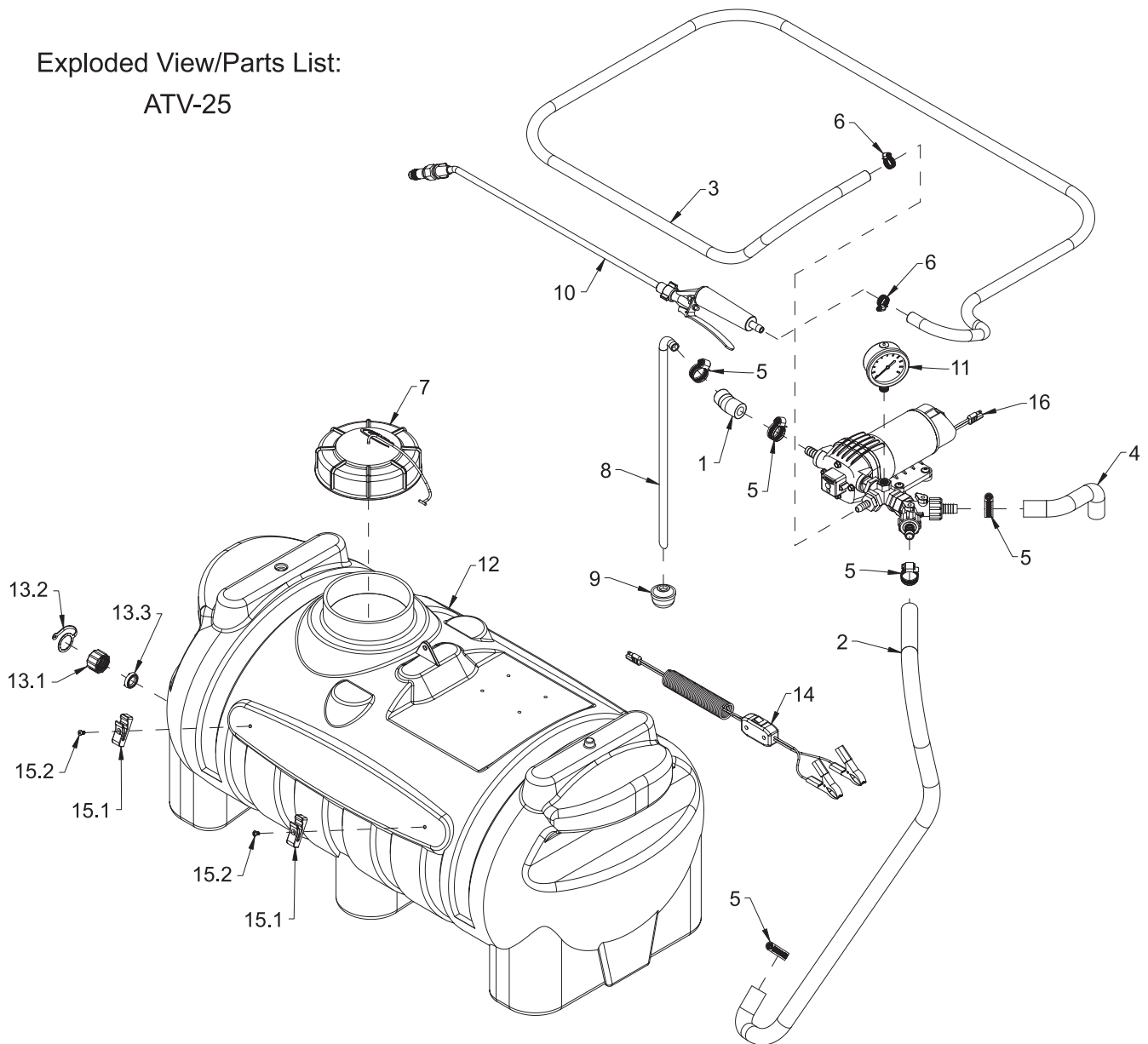

Item No.	Part Number	Qty	Description	List Price
1	5020060	1	Hose, 1/2"-1 Brd. x 2 3/4"	.64
2	5020122	1	Hose, 1/2"-1 Brd. x 48"	5.88
3	5020215	1	Hose, 3/8"-1 Brd. x 15 Ft.	8.50
4	5020241	1	Hose, 1/2"-1 Brd. x 6"	1.51
5	5051022	5	Hose Clamp, 1/2"	.62
6	5051114	2	Hose Clamp, 3/8"	.63
7	5058183	1	FIMCO 5" Threaded Tank Lid w/Lanyard	10.50
8	5100275	1	Intake Tube (25 Gallon)	1.40
9	5116251	1	Strainer, Suction Line	1.99
10	5163100	1	Low Flow Handgun w/X-26 Adjustable Tip, 29 1/2" Wand	9.95
11	5167031	1	Gauge, Liquid-Filled, 0-100# p.s.i.	14.50
12	5169206	1	25 Gallon Blowmolded Tank (w/2 Holes)	64.95
13	5274373	1	Drain Plug Cap, Tether, and Washer Assembly	2.95
13.1	5102117	1	Drain Plug Cap	.99
13.2	5058171	1	Drain Cap Tether	.30
13.3	5072507	1	Drain Cap Washer	.20
14	5274443	1	Lead Wire Assembly (w/Switch), 96"	13.50
15	5274880	1	Pkg. (2) Handgun Clips & (2) Screws	2.85
15.1	5053096	2	Handgun Clip, for Blow-Molded Tanks	.95
15.2	5117293	2	#10-24 x 3/8" Phillips Round Head Machine Screw	.25
16	5274882	1	Pump Assembly (LG-3025 & ATV-25-71)	162.72