

OWNER'S MANUAL

Model: TR-30-EX (5301486)

(30 Gallon Lawn & Garden Trailer Sprayer)

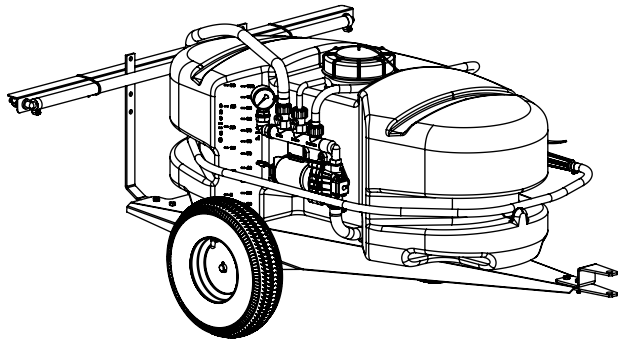

**BEFORE RETURNING THIS PRODUCT
FOR ANY REASON, PLEASE CALL**

1-800-831-0027

**IF YOU SHOULD HAVE A QUESTION OR
EXPERIENCE A PROBLEM WITH YOUR
FIMCO INDUSTRIES PRODUCT:**

1-800-831-0027

**BEFORE YOU CALL, PLEASE HAVE THE
FOLLOWING INFORMATION AVAILABLE:
SALES RECEIPT & MODEL NUMBER. IN MOST
CASES, A FIMCO INDUSTRIES EMPLOYEE CAN
RESOLVE THE PROBLEM OVER THE PHONE.**

General Information

Thank you for purchasing this FIMCO product. The purpose of this manual is to assist you in operating and maintaining your lawn & garden trailer sprayer. Please read it carefully, as it furnishes information which will help you achieve years of trouble-free operation.

Warranty/Parts/Service

Products are warranted for one year from date of purchase against manufacturer or workmanship defects.

Commercial users have a 90 day warranty.

Your authorized dealer is the best source of replacement parts and service. To obtain prompt, efficient service, always remember to give the following information...

- Correct Part Description and/or part number.
- Model number/Serial number of your sprayer.

Part descriptions and part numbers can be obtained from the illustrated parts list section(s) of this manual.

Whenever you need parts or repair service, contact your distributor/dealer first. For warranty work, always take your original sales slip, or other evidence of purchase date, to your distributor/dealer.

Technical Specifications

- 30 Gal. Corrosion-Resistant Polyethylene Tank
- 12 Volt Diaphragm Pump, 2.1 g.p.m. / 60 p.s.i.
- Lever Handgun w/15 Ft. Handgun Hose (3/8" I.D.)
- 18 Ft. max. vertical throw, 30 Ft. max. horizontal throw
- Low Profile Trailer & Tank
- 4.10/3.50 x 6" Pneumatic Tires
- Pressure Gauge
- Adjustable Pressure
- 2-Nozzle Boom Assembly (80" Spray Coverage)

Assembly

Your sprayer has been partially assembled at the factory. Follow the instructions below to complete the assembly of this unit. (Refer to the exploded view drawing later in this manual)

1. Bolt the hitch brackets, both formed and flat, to the trailer frame.
2. Slide the axle through the frame holes, centering it as best as possible.
3. Slide a wheel spacer and a wheel (valve stem out) onto each end of the axle, then use a cotter pin to secure the wheels in place.
4. Bolt the boom brackets to the back of the frame.
5. Bolt the boom assembly to the boom brackets with the tips of the boom facing rearward. The tips need to be approximately 18" above the spraying surface. Secure in place with (2) bolts and nuts provided.
6. Thread the pressure gauge into the end of the manifold assembly. Use a good grade of thread sealant, to insure no leaks.
7. Remove the drain plug & handgun clips, and attach them to the tank, as shown.
8. Attach the 'loose' boom feeder hose to the center hose barb on the manifold assembly and to the nylon feeder "tee" on the boom. Secure in place with 1/2" hose clamps.
9. Connect the electrical hook-up to the end of your pump and clip the clips to a fully charged battery. The red wire must be connected to the positive (+), and the black wire should be connected to the negative (-).

*** IMPORTANT REMINDER ***

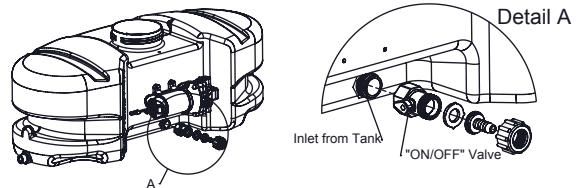

This unit comes with an On/Off valve, located near the inlet of the tank, towards the underside. (See Detail A)
You must make sure the valve is in the "open" position before using your unit.



www.fimcoindustries.com

1000 FIMCO Lane, P.O. Box 1700, North Sioux City, SD 57049
Toll Free Phone: 800-831-0027 : Toll Free Fax: 800-494-0440

Form No. 1325 [5004818 (03/09)] Printed in the U.S.A.

Testing the Sprayer

NOTE:

It is **VERY** important for you to test your sprayer with plain water before actual spraying is attempted. This will enable you to check the sprayer for leaks, without the possibility of losing any expensive chemicals.

Add water to the tank & drive to the starting place for spraying. When you are ready to spray, turn the boom valve to the "on" position. This will start solution spraying from the tips of the boom. The pressure will decrease slightly when the boom is spraying. Adjust the pressure by turning the "ON/OFF" valve lever on the bypass line valve.

Read the operating instructions and Initially begin spraying by closing the 'bypass' valve (this is the center ON/OFF valve located at the center port of your manifold assembly) and opening the boom line valve (this is the 'other' valve on the manifold). This will enable the air in the line to be eliminated (purged) through all the tips, while building pressure. When everything tests all right (no leaks, & good pressure), add the desired chemicals to the mixture and water combination and start your spraying operation. Adjust the pressure and spray as you did in the testing procedure.

Conditions of weather and terrain must be considered when setting the sprayer. Do not spray on windy days. Protective clothing must be worn in some cases.

Be sure to read the chemical label(s) correctly!

Calibration

Chemical labels may show application rates in gallons per acre, gallons per 1000 square feet, or gallons per 100 square feet. You will note that the tip chart shows all 3 of these rating systems.

Once you know how much you are going to spray, then determine (from the tip chart) the spraying pressure (PSI), and the spraying speed (MPH).

Determining the proper speed of the pulling vehicle can be done by marking off 100, 200, & 300 feet. The speed chart indicates the number of seconds it takes to travel the distances. Set the throttle and with a running start, travel the distances. Adjust the throttle until you travel the distances in the number of seconds indicated by the speed chart. Once you have reached the throttle setting needed, mark the throttle location so you can stop and go again, returning to the same speed.

Add water and proper amount of chemical to the tank and drive to the starting place for spraying.

Speed Chart			
	Time Required in seconds to travel a distance of:		
Speed in M.P.H. (Miles per Hour)	100 Ft.	200 Ft.	300 Ft.
1.0	68 sec.	136 sec.	205 sec.
2.0	34	68	102
3.0	23	45	68
4.0	17	34	51
5.0	14	27	41
6.0	11	23	34
7.0	9.7	19	29
8.0	8.5	17	26
9.0	7.6	15	23
10.0	6.8	14	20

Operation

Your sprayer is equipped with (2) ON/OFF switches. One is on the wire assembly that you hook up to your battery, the other is on the pump itself, on the opposite end of the pressure switch. The "-" is the "ON" position and the "o" is the "OFF" position for the switches. Make sure both switches are depressed in the "-" position for operation.

In addition to the ON/OFF switch, the pump is equipped with an electronic pressure switch that is factory pre-set for it to shut off at 60 p.s.i.. This switch assembly is the 'square box' on the head portion of the pump.

Always fill the tank with a desired amount of water first, and then add the chemical slowly, mixing as you pour the chemical into the tank. You may use the handgun to spray into the solution in order to mix the chemical and water.

Initially begin spraying by opening the handgun. This will enable the air in the line to be purged through the handgun tip, while building pressure.

The pumping system draws solution from the tank, through the strainer/filter, and to the pump. The pump forces the solution under pressure to the handgun and/or boom nozzles.

- Open the handgun by squeezing the handle lever.
- Rotating the adjustable nozzle tip on the handgun will change the tip pattern from a straight stream to a cone pattern (finer mist).

NOTE: Make sure the tires are inflated to 30 psi prior to use.

Tip Chart										
Tip No.	Spray Height	Pressure (psi)	Capacity (GPM)	Gallons Per Acre - Based on Water						
				1 MPH	2 MPH	3 MPH	4 MPH	5 MPH	7.5 MPH	10 MPH
3	18"	10	.30	44	22	14.9	11.1	8.9	5.9	4.5
		20	.42	63	31.5	20.9	15.7	12.6	8.4	6.3
		30	.52	76	38	26	19.3	15.4	10.3	7.7
		40	.60	90	45	30	22	17.8	11.8	8.9
Tip No.	Spray Height	Pressure (psi)	Capacity (GPM)	Gallons Per 1000 Sq. Ft. - Based on Water						
				1 MPH	2 MPH	3 MPH	4 MPH	5 MPH	7.5 MPH	10 MPH
3	18"	10	.30	1.01	.50	.34	.254	.204	.135	.103
		20	.42	1.4	.72	.48	.36	.29	.19	.14
		30	.52	1.74	.87	.596	.44	.35	.236	.176
		40	.60	2.06	1.00	.688	.50	.408	.27	.20
Tip No.	Spray Height	Pressure (psi)	Capacity (GPM)	Gallons Per 100 Sq. Ft. - Based on Water						
				1 MPH	2 MPH	3 MPH	4 MPH	5 MPH	7.5 MPH	10 MPH
3	18"	10	.30	.10	.05	.034	.025	.02	.013	.01
		20	.42	.14	.072	.048	.036	.029	.019	.014
		30	.52	.174	.087	.059	.044	.035	.023	.017
		40	.60	.206	.10	.068	.05	.04	.027	.02

CAUTION

PRESSURE SWITCH OPERATION

Pressure switch is pre-set at the factory. Improper adjustment of the pressure switch, may cause severe overload or premature failure. If the pump is subjected to rapid cycling during normal operation, or infrequent periods, damage may occur.

After Spraying

After use, fill the sprayer tank part way with water. Start the sprayer, and allow the clear water to be pumped through the plumbing system and out through the spray nozzles.

Refill the tank about half full with plain water and use a chemical neutralizer, such as 'Nutra-Sol', or equivalent, and repeat cleaning instructions above. A mix of water and some detergent, such as 'Dawn' dish soap would be a sufficient alternative.

Flush the entire sprayer with the neutralizing/cleaning agent, then flush out one more time with plain water. Follow the chemical manufacturer's disposal instructions of all wash or rinsing water.

For the boom, (if applicable) remove the tips and screens from the nozzle assemblies. Wash these items out thoroughly. Blow the orifice clean and dry. If the orifice remains clogged, clean it with a fine bristle (NOT WIRE) brush, or with a toothpick. Do not damage the orifice. Water rinse and dry the tips before storing.

WARNING: Some chemicals will damage the pump valves if allowed to soak untreated for a length of time! ALWAYS flush the pump as instructed after each use.

Troubleshooting a 2.1 g.p.m. Pump:

Pump will NOT run:

- Check inline fuse on the wires on the pump. If blown, replace with new fuse. (7.5 Amp mini-blade fuse #5157205)
- Make sure BOTH on/off switches are in the 'on' position (-).
- Make sure you 12 volt source (battery) is fully charged.
- Insure a tight connection at the battery clips.

If none of the above will work, try pulling wire terminal "A" off of the spade terminal of the pressure switch, and cross it over and touch terminal "B". (You will need to remove the pressure switch cap before doing this) If your pump runs when you do this, you know you will need to replace your pressure switch.

Another thing you can try is to take apart the switch box on the lead wire assembly (#5274443) with the (2) phillips head screws, and 'hot-wire' it together. Take the (2) wires that are screwed to the rocker switch, off of the switch and twist them together. This will insure you are getting the full 12 volts to the pump. If your pump runs after doing this, you will know that your lead wire assembly needs to be replaced.

Winter Storage

Drain all water out of your sprayer, paying special attention to the pump, handgun, and valve(s). These items are especially prone to damage from chemicals and freezing weather.

The sprayer should be winterized before storage by pumping a solution of RV antifreeze through the entire plumbing system. This antifreeze solution should remain in the plumbing system during the winter months. When spring time comes and you are preparing your sprayer for the spray season, rinse the entire plumbing system out, clearing the lines of the antifreeze solution. Proper care and maintenance will prolong the life of your sprayer.

Pump runs, but does not prime:

- Check line strainer (screen) at the inlet location, at the tank. You will need to unscrew the knurled nut to access this screen. (see exploded view later in this manual) The ON/OFF valve should be closed while performing this, to insure you do not lose any solution. Periodically take the screen at this location out and clean it.
- Make sure the bypass line valve is closed, to allow the pressure to build up in your system.
- Unscrew the head portion of your pump and remove the check valve assembly from inside. You need to make sure the O-Ring comes out with this piece as well. (See the exploded view to help identify these components) These pieces can be cleaned which, in most cases, will help restore some, if not most, of your prime. Soak this check valve in a solution of hot, soapy water. "Dawn" brand dishsoap works well for this. A little bit of 'scrubbing' with perhaps an old toothbrush may be required to actually break up any build-up that may be on the check valve. Rinse off the pieces and replace them back into your pump. Reassemble the pump. Hook it back up and test.

#5275703 Pump (12 Volt, 8 Amp, 2.1 gpm, 60 psi)

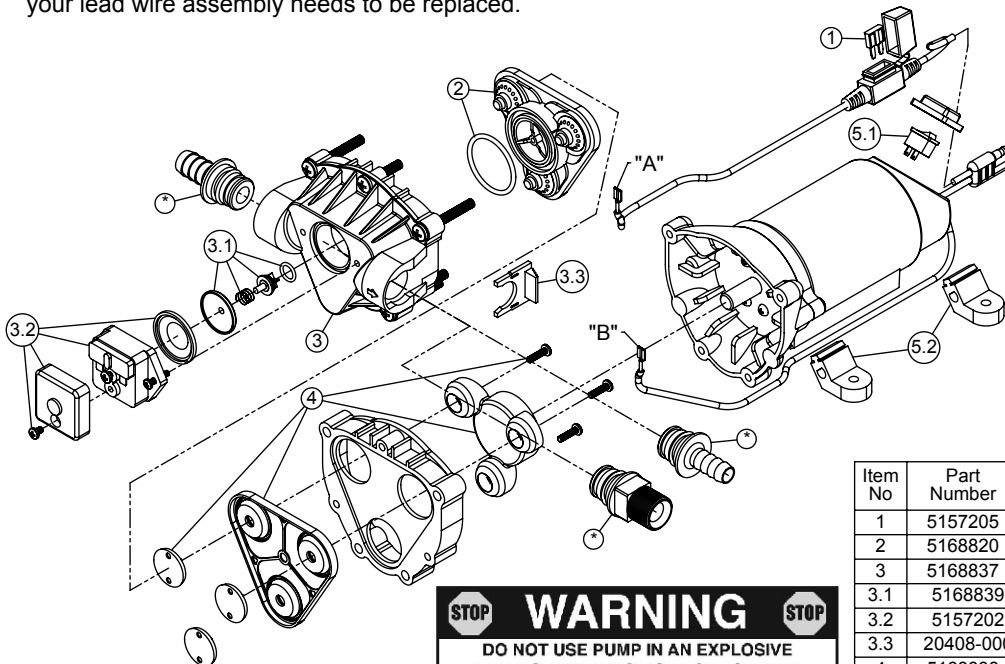

Fittings with an asterisk (*) by them, come together in a bag, part #7771824

- (1) 5168832 - 1/2" MNPT
- (1) 5168833 - 1/2" Hose Barb
- (1) 5168836 - 3/8" Hose Barb

STOP WARNING STOP
DO NOT USE PUMP IN AN EXPLOSIVE ENVIRONMENT. DO NOT USE TO PUMP FLAMMABLE FLUIDS, GASOLINE, KEROSENE, FUEL, OIL, ETC.

Item No	Part Number	Qty	Description	List Price
1	5157205	1	7.5 Amp Mini Fuse	1.00
2	5168820	1	Check Valve Kit (w/O-Ring)	19.95
3	5168837	1	Upper Housing Assembly	39.95
3.1	5168839	1	Plunger Kit	12.99
3.2	5157202	1	Pressure Switch Assembly	23.95
3.3	20408-000	1	Pkg. (2) Clips (Port Fitting)	3.41
4	5168838	1	Diaphragm/Cam/Bearing Kit	18.99
5.1	5157207	1	Rocker Switch	6.99
5.2	5095202	4	Pump Foot (1.0 & 2.1 g.p.m.)	1.29

Exploded View/Parts List: TR-30-EX (5301486)

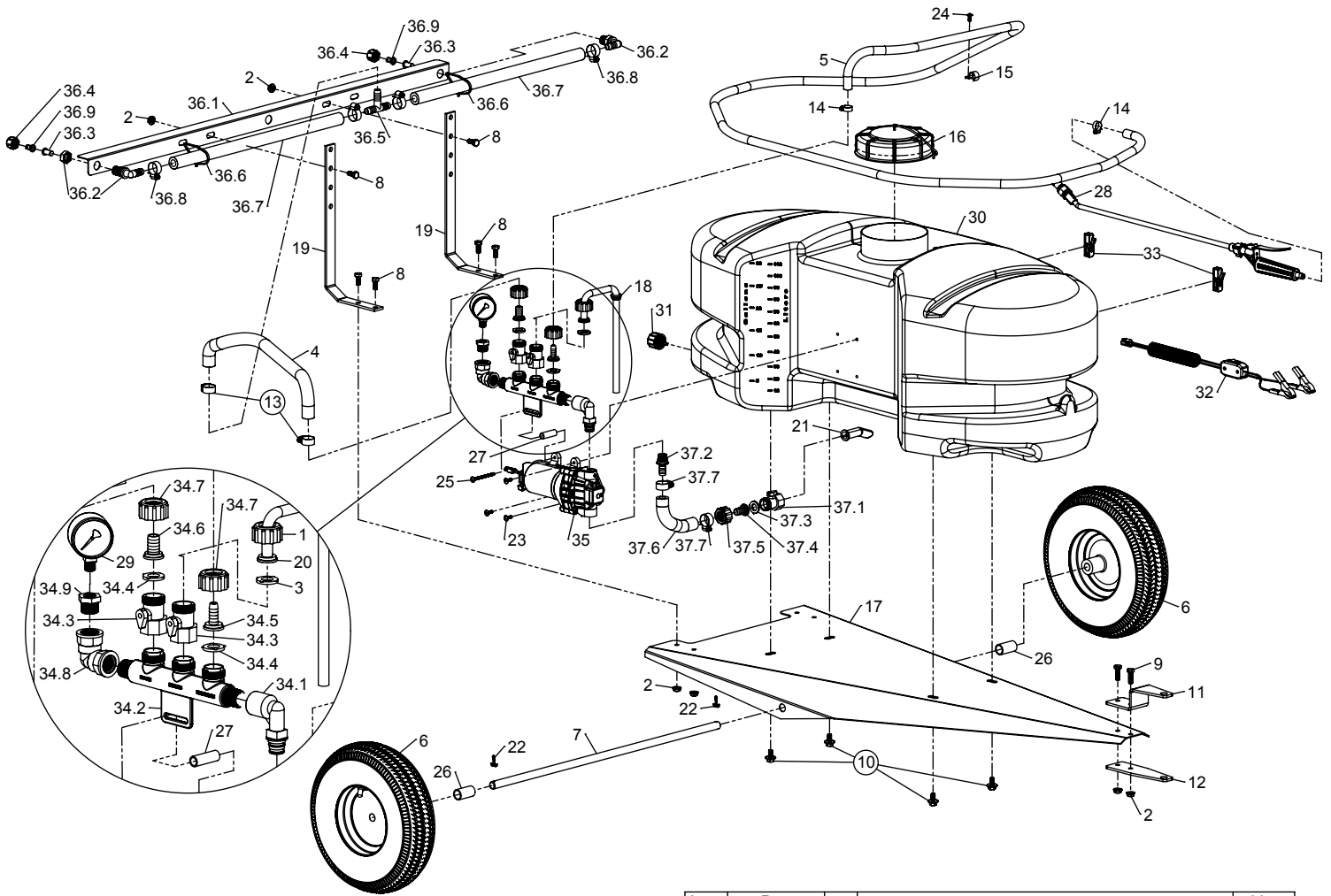

Item No	Part Number	Qty	Description	List Price
1	5006209	1	Poly Knurled Swivel Nut, 3/4" FGHT	.57
2	5006307	8	5/16"-18 Hex Whiz (Flange) Locknut	.25
3	5016066	1	Garden Hose Washer	.20
4	5020009	1	Hose, 1/2"-1 Brd. x 26"	2.66
5	5020215	1	Hose, 3/8"-1 Brd. x 15 Ft.	8.50
6	5021102	2	4.10/3.50-6 Wheel (White) w/2 1/4" Offset & 5/8" BB	29.95
7	5024102	1	Axle (5/8" Dia.)	8.11
8	5034038	6	H.H.C.S., 5/16"-18 x 3/4"	.55
9	5034042	2	H.H.C.S., 5/16"-18 x 1"	.25
10	5034531	4	5/16"-18 x 5/8" Flange Lock Screw	.44
11	5038517	1	Hitch Bracket (Formed)	4.85
12	5038518	1	Hitch Bracket (Flat)	2.30
13	5051022	2	Hose Clamp, 1/2"	.62
14	5051114	2	Hose Clamp, 3/8"	.63
15	5051122	1	5/8" Black Nylon Loom Cable Clamp	.25
16	5058188	1	Tank Lid w/Lanyard	10.50
17	5070063	1	Trailer Frame (RED: 25 & 30 Gal. "New" Style Tanks)	45.15
18	5075018	1	Grommet	1.00
19	5095198	2	Boom Bracket (Light Duty)	2.00
20	5100359	1	Poly Bypass "J" Hose (3.8 Pumps & 2.1 [25] Gallon)	1.95
21	5100452	1	Siphon Tube	1.20
22	5101077	2	Cotter Pin, 1/8" x 1"	.25
23	5117167	3	#10-24 x 5/8" Phillips Truss Head Machine Screw	.25
24	5117234	1	#10-24 x 1/2" Phillips Truss Head Machine Screw	.25
25	5117313	1	#10-24 x 2 1/2" Truss Head Machine Screw	.25
26	5127189	2	Bushing (25/30 Gallon Trailer)	.50
27	5127191	1	Manifold Spacer (2.1gpm)	.40
28	5163100	1	Low-Flow Handgun w/X-26 Tip	9.95
29	5167007	1	Gauge, 0-100 p.s.i.	6.25

Item No	Part Number	Qty	Description	List Price
30	5169244	1	30 Gallon (New Style) Tank	65.00
31	5274373	1	Drain Plug Cap, Tether, and Washer Assembly	2.95
32	5274443	1	Lead Wire Assembly (w/Switch), 96"	9.99
33	5274880	1	Pkg. (2) Handgun Clips & (2) Screws	2.85
34	5275516	1	Manifold Assembly	18.00
34.1	5010430	1	Port Kit Elbow, 1/2" FNPT	2.79
34.2	5143405	1	Manifold w/Mounting Tab	6.99
34.3	5143188	2	Nylon Shut-Off Valve	3.10
34.4	5016066	2	Garden Hose Washer	.20
34.5	5149034	1	Poly Swivel, 3/8" Hose Barb	.50
34.6	5149035	1	Poly Swivel, 1/2" Hose Barb	.50
34.7	5006209	2	Poly Knurled Swivel Nut, 3/4" FGHT	.57
34.8	5010236	1	Poly Elbow, 1/2" FNPT x 1/2" FNPT	2.07
34.9	5041073	1	Poly Reducing Bushing, 1/2" MNPT x 1/4" FNPT	1.24
35	5275703	1	Gold Series 2.1 g.p.m. Pump	112.00
36	5275726	1	2-Nozzle Boom Assembly	26.01
36.1	5022411	1	Boom Mount Angle	5.85
36.2	5056023	2	Nylon Elbow Assembly, 11/16" U.N.F. x 1/2" HB	1.35
36.3	5116019	2	50 Mesh Nozzle Strainer, Red	1.05
36.4	5046052	2	Nylon Nozzle Cap, 11/16" U.N.F. Thread	.38
36.5	5086003	1	Nylon Hose Tee, 1/2" HB	.88
36.6	5133094	2	Nylon Cable Tie	.25
36.7	5020416	2	Hose, 1/2"-1 Brd. x 19 3/8"	2.17
36.8	5051022	4	Hose Clamp, 1/2"	.62
36.9	5018327	2	FloodJet Tip	2.41
37	5275877	1	Intake Sub-Assembly	7.49
37.1	5143188	1	Nylon Shut-Off Valve	3.10
37.2	5168833	1	Port Kit Fitting, 1/2" Hose Barb	2.24
37.3	5116242	1	Strainer, 1" Filter Washer	.31
37.4	5149035	1	Poly Swivel, 1/2" Hose Barb	.50
37.5	5006209	1	Poly Knurled Swivel Nut, 3/4" FGHT	.57
37.6	5020497	1	1/2" Polyspring Hose x 6"	1.69
37.7	5051022	2	Hose Clamp, 1/2"	.62

(List Prices are Subject to Change)