

AGRICULTURE

25 BUSHEL MANURE SPREADER

MS-25BU

MANURE SPREADER

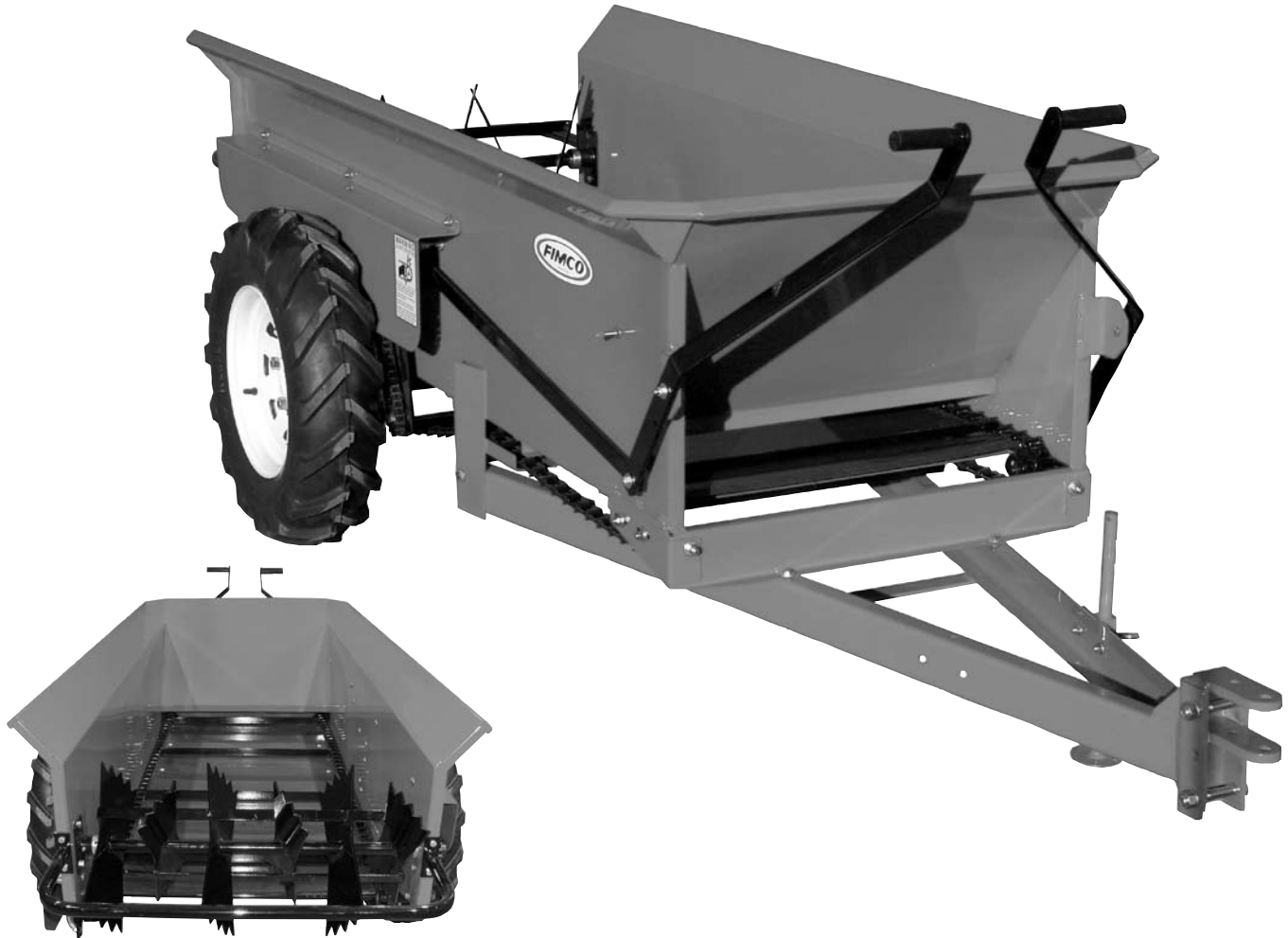

Model #	Code #	Box Size	Weight	Carton Size	Shipping Class	Cubic Feet	UPS able	UPC Code	List Price
MS-25BU	5301194	25 Bushels	464	93 x 42 x 33	010255-Sub-2-85	35.0	NO	733029002754	\$2,809.00

DESCRIPTION

The box on this unit has a 25 bushel capacity. The chain conveyor and rear rotary blades enable the spreading of the loaded manure.

FEATURES

- Tongue Extends 33 Inches In Front Of Box Frame
- Chain Driven Mechanisms
- Handy Lever Controls To Engage Chain & Rotary Blades
- Safety Shields For Ground Drive Mechanisms
- Corrosion Resistant Bed Floor
- Width (Overall): 48"
- Height (Overall): 31"
- Length (Overall): 9 FT. 9"
- Box Dimensions: 72"L x 28"W x 18 1/2" H